

GS

3-Axis Stabilized Handheld Gimbal
Compatible with GoPro HERO5 / HERO4 / HERO3+ /
HERO3 / Yi Cam 4K / AEE etc.

Guilin Feiyu Technology Incorporated Company

1. Product Overview

* The showing sports camera is only for reference

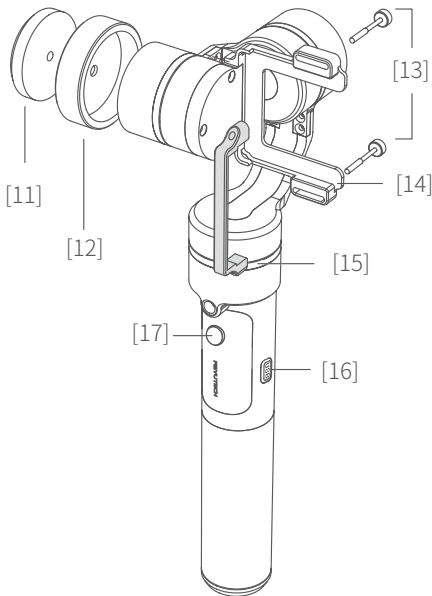
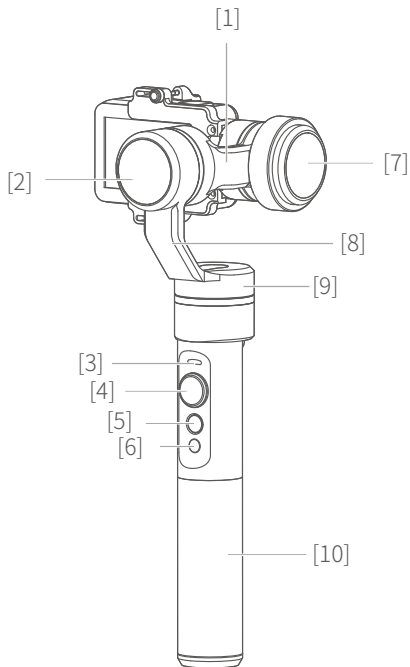

- [1] Cross arm
- [2] Rolling axis
- [3] Status indicator
- [4] Joystick
- [5] Function button
- [6] Self-timer button
- [7] Titling axis
- [8] Vertical arm
- [9] Panning axis
- [10] Handle
- [11] Counter weight
- [12] Weight ring
- [13] Thumb screw
- [14] Retainer plate
- [15] Retainer bar
- [16] USB interface
- [17] Trigger button

Package List



HERO 5 camera
charging cable X1



Mini camera
charging cable X1



USB cable X1



Thumb screw X2



Battery
(Type:22650) X1



Portable bag X1

Water Splash Proof



App Control

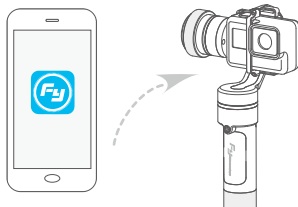

Compatible with Accessories

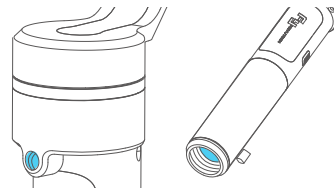

*Never submerge the gimbal in water

2. User Guide

Attention: Please complete the following instructions before powering on the gimbal.

1 Install the battery

Remove the handle and insert one 22650 battery into it.

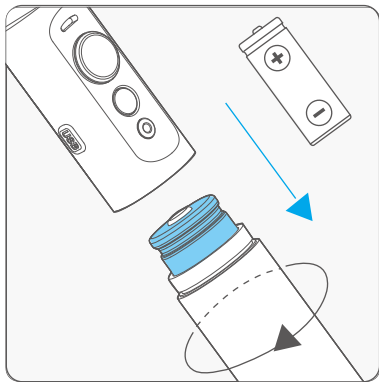

2 Install the Camera

Take the Gopro HERO 5 camera for example

Install the camera on retainer plate, then fix the camera with retainer bar and screw.

option 1

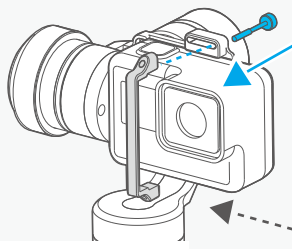

1-normal position

option 2

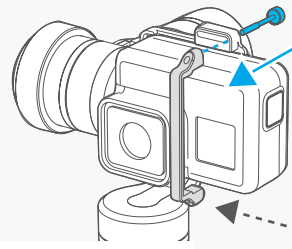

2-reverse position

3 Camera balance adjustment

In order to achieve in a better performance of the gimbal, please try to balance the camera before powering on G5.

Balance adjustment reference :

GoPro HERO 5 — counter weight & weight ring

GoPro HERO 4 — counter weight

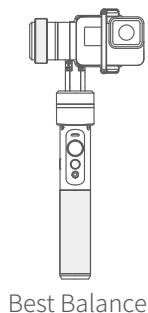
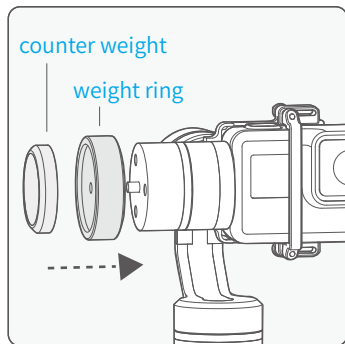

4 Power on / off

Attention: Make sure the camera is secure before powering on the Gimbal.

Power On: Press and hold the function button until the green light comes on and you hear the tone.

Power Off: Press and hold the function button until the red light changes from quick flashing to constant and you hear the tone.

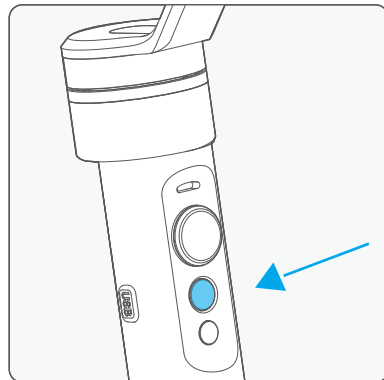

In case of low battery the indicator light will flash red three times every 5 seconds. Please charge gimbal or replace the battery.

3. Modes / Functions

Mode / Function Operation Instructions

Function Button	Function	Explanation
One tap	Panning follow / Locking Mode	Single tap to switch between panning follow and locking mode
Two taps	All follow	Under all follow, single tap to switch to locking mode
Three taps	Rotate horizontal 180°	Make the lens rotate 180°
Four taps	Autorotation Mode	Quadruple taps to enter autototation mode
Five taps	Initialization	Five taps to automatically enter initialization
Trigger Button	Function	Explanation
Long press	Locking Mode	In the panning follow or all follow, press and hold the button to enter the locking mode, release it to return previous mode
Two taps	Panning Reset	Restore the initial follow state of the panning follow

Explanation of LED indicator status

The current mode of the gimbal can be identified by the indicator status.

Indicator status	Mode / Status
Blue light flashes once	Panning follow
Blue light flashes twice	All follow
Blue light constant on	Locking mode / Initialize the gimbal
Blue light keeps flashing	Initialization failure / Malfunction
Red light flashes three times	Low battery
Red light keeps flashing	Entering power off

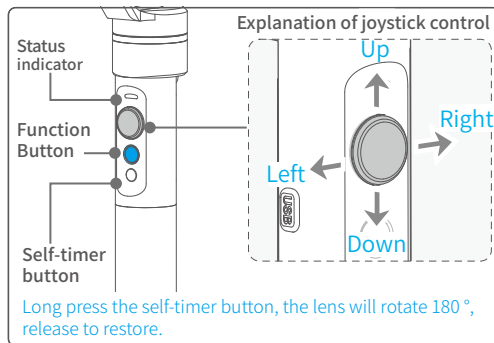

Working Modes

Panning follow

All direction are fixed, and the camera lens moves according to the hand movement direction of the user.

*The gimbal will work in panning follow after powering on.

All follow

The rolling direction is fixed, and the camera lens moves according to the hand movement direction of the user.

Locking Mode

The orientation of the camera is fixed.

Reset

Return to panning follow, all to return to default.

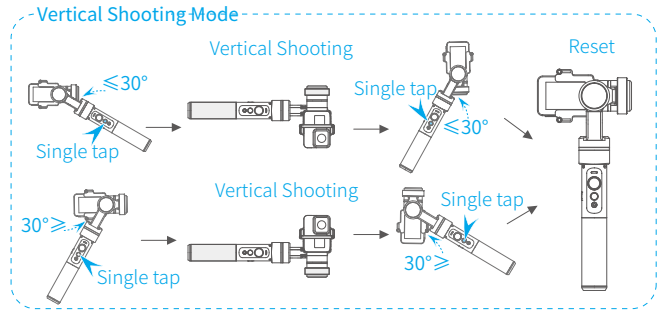

Audio effect optimization

When installing GoPro HERO5 on G5, the following configuration of HERO5 will help you to get better audio effect:

[RAW AUDIO TRACK] HIGH

RAW AUDIO TRACK

Applies full audio processing including wind and/or stereo and automatic gain.

MID

HIGH



[MANUAL AUDIO CONTROL] Wind Only

MANUAL AUDIO CONTROL



Wind Only



Stereo Only



Autorotation Mode

1. Four taps on function button, gimbal will access the autorotation mode .
 2. Set the gimbal rotation start position: Pull the tilting axis or panning axis to the start position by hand,clicking the function button to record.
 3. Set the gimbal rotation end position:Pull the gimbal (which can be rotated more than one turn) to the rotation path you want to set, and then click the function button to record the end position .
 - 4.The gimbal will go to the start position and start the automatic rotation.
- Using the gimbal autorotation function with a camera, timelapse photography functioning can be used to achieve special movement timelapse photography.use the Feiyu ON App for control the speed setting .

Note: Both the panning and tilting directions can be rotated.

Exit operations:

- 1.Click the function button to exit the autorotation mode during automatic rotation and reset the gimbal.
- 2.Enter the autorotation mode or autorotation setting, four times click the function button to exit the autorotation mode and reset the gimbal.

Annexed parameter table:

gimbal speed setting reference table

G5 speed setting
8 hours / turn
4 hours / turn
2 hours / turn
1 hour / turn (default)
30 minutes / turn
15 minutes / turn
8 minutes / turn
4 minutes / turn
2 minutes / turn
1 minute / turn
30 seconds / turn
15 seconds / turn

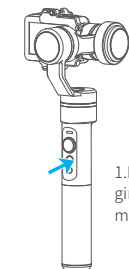

1. Four taps on function button, gimbal will access the autorotation mode setting.

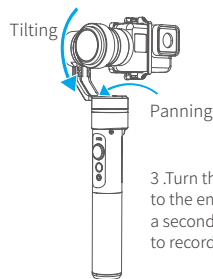

3. Turn the panning axis or tilting axis to the end position and hold for half a second. Click on the function button to record the end position .

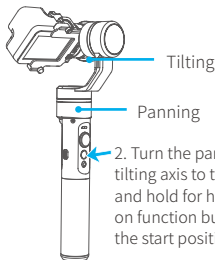

2. Turn the panning axis or tilting axis to the start position and hold for half a second. Click on function button to record the start position .

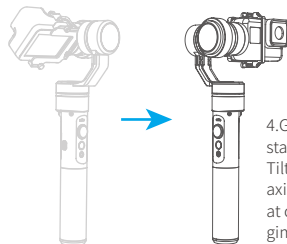

4. Gimbal will recover to start position automatically. Tilting axis and panning axis turn to end position at constant speed. The gimbal is automatically reset after the end.

Manual Lock

Pull to the required angle and hold for half a second to lock in that position. (The tilting axis and panning axis in the locking mode can be manual locking. The tilting axis can be manually locked in the panning follow.) Take the tilting axis as an example :

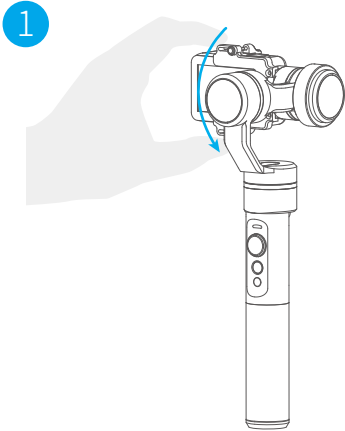

Hold the camera and change its angle in tilting axis direction.

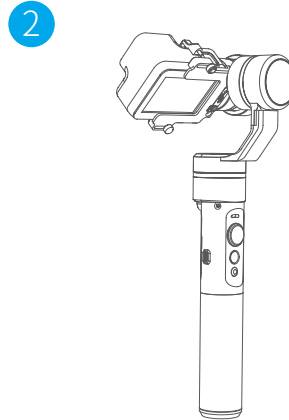

Keep this position for half second, the current angle will be locked manually.

4. Download and connect App

1 Download " Feiyu ON " and install it.

Please download Feiyu ON at your smartphone app store or can the QR code below.

* Requires iOS 9.0 or later, Android 6.0 or later.



iOS Version



Android Version

2 Connecting App

Start the App on your smartphone, follow the instructions to connect the smartphone with gimbal via bluetooth.

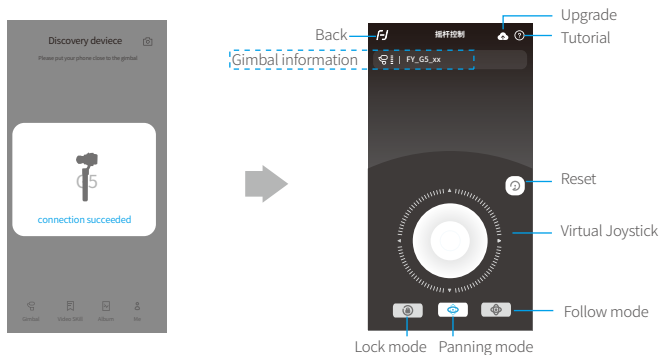

5. Charging

1 Gimbal charging

* Please make sure the battery was fully charged before you power on the gimbal first time.

Option 1: charging with micro USB cable.

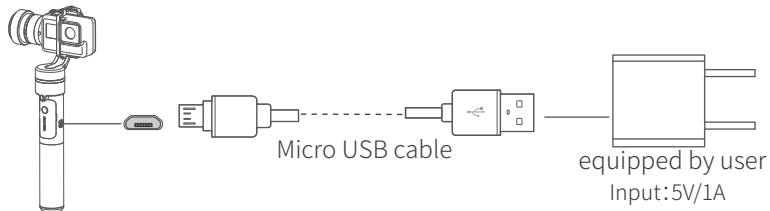

Option 2: remove the battery and charge the battery with charger(equipped by user).

2 Charging for Camera

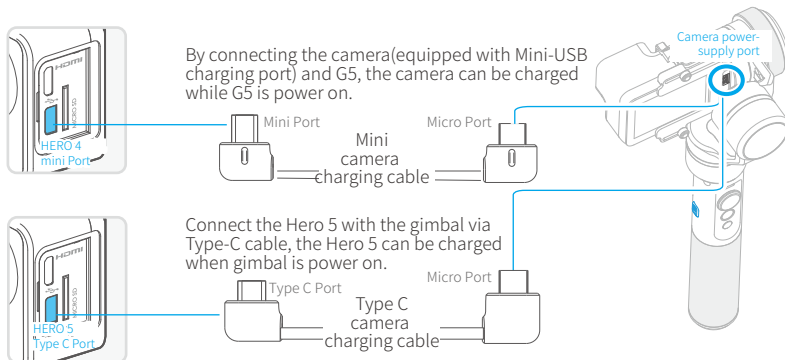

6. Firmware Upgrade

Upgrade the firmware through the Feiyu ON App.

(1) Click the icon 

(2) Select upgrade type.

(3) Follow the prompts to upgrade the firmware.

Upgrade type introductions:

Gimbal update: Repair / update or newly add gimbal control / function / parameter and etc.

Keyboard update: Repair / update or newly add button/touch screen/interaction functions, update more compatibility cameras which can be controlled through WIFI, repair few bugs about camera control through WIFI, and etc.

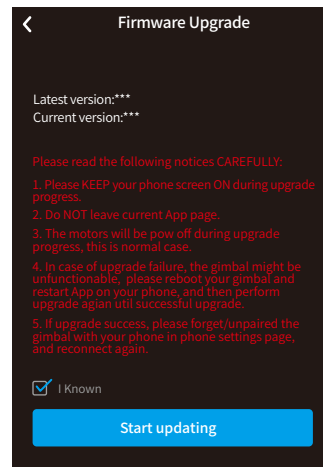

7. Gimbal initialization

You can initialize your gimbal when:

- (1) camera is not level.
- (2) if not used for a long period of time.
- (3) in case of extreme temperature variations.

Adjusting steps:

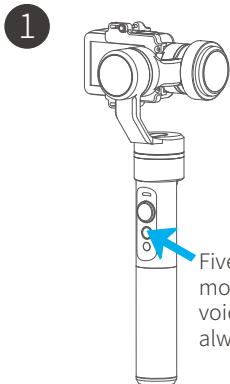

2

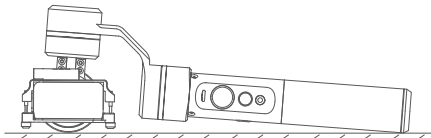

Place the gimbal still on a desktop. The gimbal will automatically initialize when it detects being static. The blue light cycles three flashes and then initialization ends, otherwise the initialization fails.

3

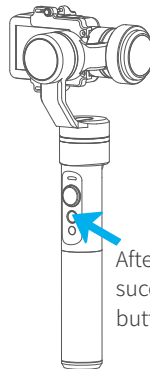

After the initialization is successful, click the function button to wake up.

Note: If the initialization is not successful for a long time, long press the function button to turn off the gimbal, restart it and then initialize.

8. Parameters

Titling Angle	360°	Titling Increments	min 2°/s max 75°/s
Rolling Angle	245°	Panning Increments	min 3°/s max 150°/s
Panning Angle	360°	Usage Time	8 Hours
Adaption	GoPro HERO5 / HERO4 / HERO3+ / HERO3 / Yi cam 4K / AEE	and other cameras with the same size	
Weight	271g (Not including battery, camera or counter weight)		

Unit: mm

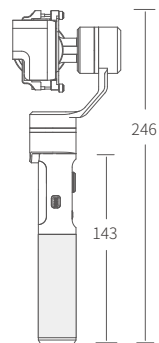
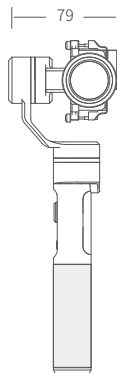
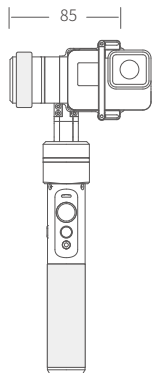
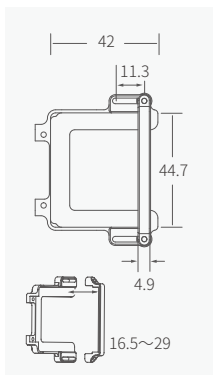

DISCLAIMER

Prohibit any user for any illegal purpose. Users will be responsible for all behaviors of purchase and use products.

The Company assumes no liability for any risks related to or resulting from the debug and use of this product (including the direct, indirect or third-party losses).

For any unknown sources of using, we will not be at any services.

The updating and changes of product firmware and program may cause changes in function descriptions in this user manual, please read the instructions carefully before upgrading the firmware and use the corresponding user manual.

You can get the latest user manual from the official website: www.feiyu-tech.com

Feiyu Tech reserves the right to amend this manual and the terms and conditions of use the gimbal at any time.

Attention

- Please correctly assemble the gimbal in accordance with the diagram
- Please install the phone before powering on the gimbal
- When the gimbal is not in use or placed on the table, please ensure it is powered off

Guilin Feiyu Technology Incorporated Company

Website: www.feiyu-tech.com **E-mail:** service@feiyu-tech.com **Tel:** +86 (0)773 2320865

Due to software and hardware improvements, your actual product might differ from the descriptions and pictures in this user manual. You can get the latest user manual from the official website.

For more information, please visit our official website

